

Date:

January 2018

Description:

Ford 10" 40-Spline Air Locker

Part No.

RD249CE

Application:

Ford 10" 40-Spline

Availability Date:

January 2018

Retail Price:

\$2235.00

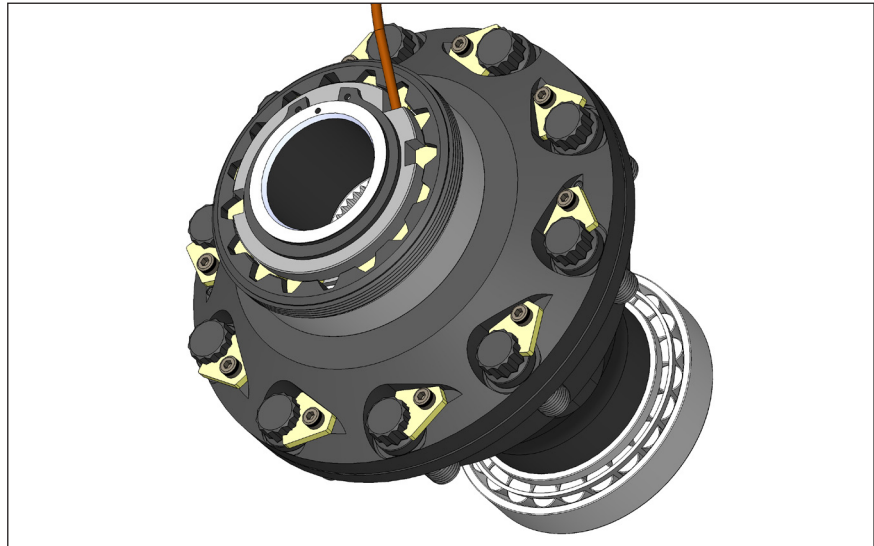

IT'S FINALLY HERE

THE MOST TECHNICALLY ADVANCED AIR LOCKER YET

After successful years of research and development and real world testing in some of the most extreme off-road racing environments, including winning the 2017 & 2018 King of the Hammers race. ARB is excited to release the long-awaited Ford 10" 40-Spline Competition Edition Air Locker.

The RD249CE Air Locker has been designed around the requirements of top-flight rock racing requiring the features of a selectable locker with ability to use 40-spline axle shafts to withstand the shock load caused by high horsepower engines and 40"+ tires.

The RD249CE carries the standard 5-year warranty. While this product was designed to withstand the demands of competition racing, the use of this, or any Air Locker, in competition racing, the use of this, or any Air Locker, in competition voids the warranty due to the severe and unpredictable nature of racing.

Features:

- High tensile castings developed for the extreme high torque and shock loading associated with top end motorsports.
- Locker case design has been optimized to pre-clear most load bolts systems.
- Drilled for 1/2" R&P bolts- 1/2" ARP R&P bolt kit included.
- Integrated ring gear bolt locking system offers superior strength and serviceability over safety wire systems.
- Tuned captive bevel gear assembly resists the adverse effects of flexing/bent or eccentric positioning of axles/stubs found in high torque motorsports applications.
- New forged gear geometry redesigned to accommodate the much larger 40-splined shafts.
- Increased lock system force for any given pressure supply and 20% increase in lock system engagement depth.
- Hardened tool steel adjuster nut for ultra high bearing thrust loads.
- All new seal housing location system designed to cope with harsh treatment in the remote pits of desert racing.
- Completely redesigned bulkhead fitting kit allows simple in-field connection and disconnection without any effect on the seal housing tube.
- New heavy gauge 6mm (black) air line.
- Engineered and manufactured in Australia.
- **Will not suit OE third members.**

USA OFFICE

ARB USA- Air Locker Inc.

STREET ADDRESS

4810 D St. NW. Suite #103
Auburn, WA 98001

CONTACT DETAILS

T 866- 293- 9078
W arbusa.com